



A Susceptible-Infected Model for Exploring the Effects of **Neighborhood Structures on Epidemic Processes – **A Segregation Analysis.****

**Leonardo B. L. Santos, Raian V. Maretto,
Líliam C. C. Medeiros, Flávia F. Feitosa,
Antônio M. V. Monteiro**

- **Spatially-explicit** models in epidemiology
 - **Cellular automata:** self-reproductive dynamic systems, where time, space and states are discretized.

- **TerraME** platform
(Terra Modeling Environment)

LUA language

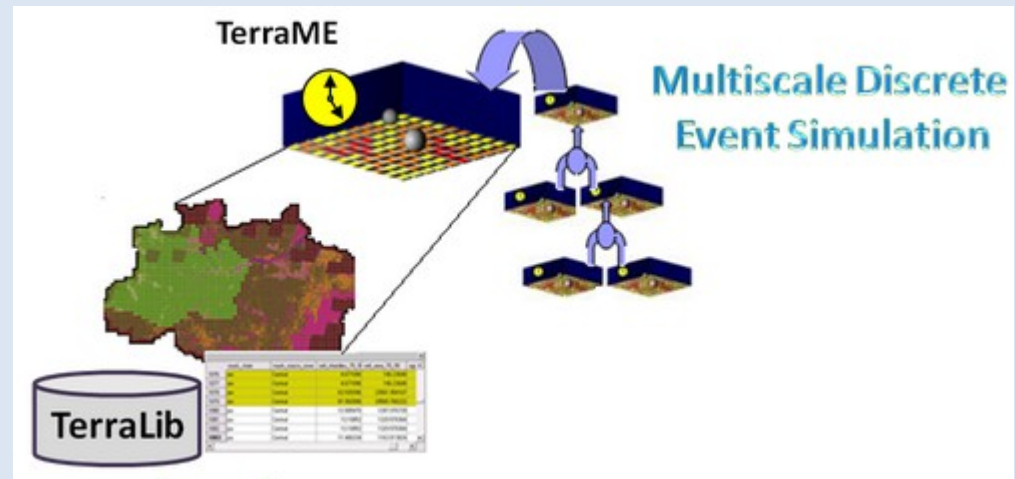

Overview

Spatial distribution of infected and susceptible individuals

Different neighborhoods and initial distribution

(a)

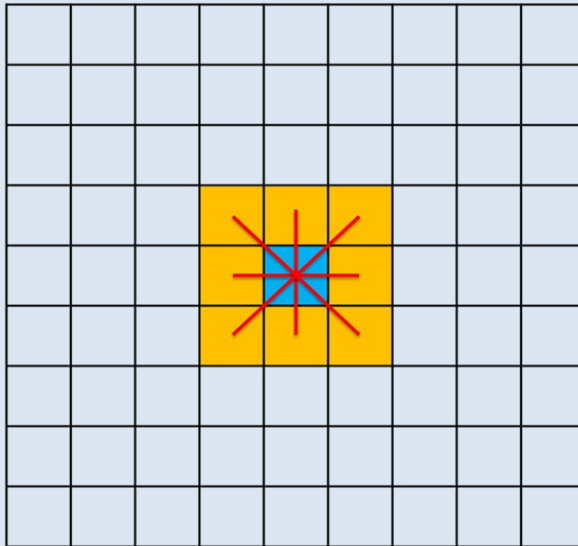

(b)

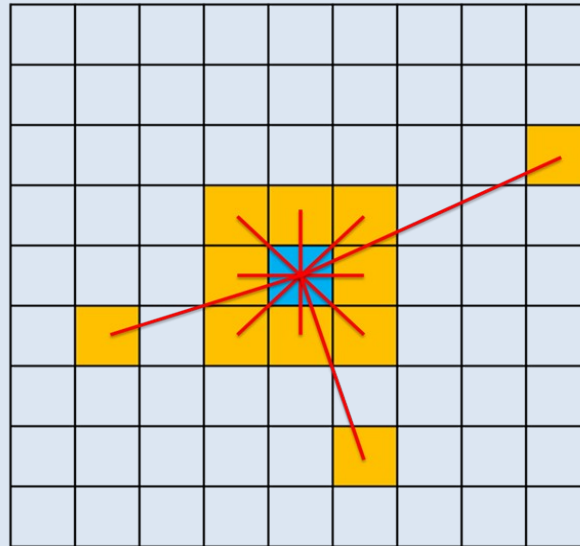

Overview

CA = (G, N, S, IC, R, BC, UC)

G: Geometry

N: Neighborhood

S: States

IC: Inicial condition

R: Rules

BC: Bondaries conditions

UC: Updating criteria

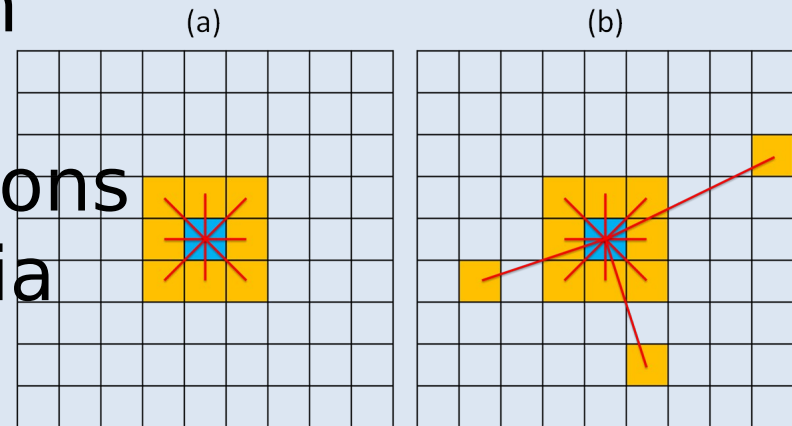
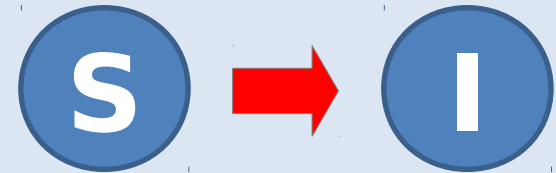

The Model Structure

In our simplification:

One cell – one individual

$$\underline{(S \rightarrow I) = F(\# I \text{ on neighborhood})}$$

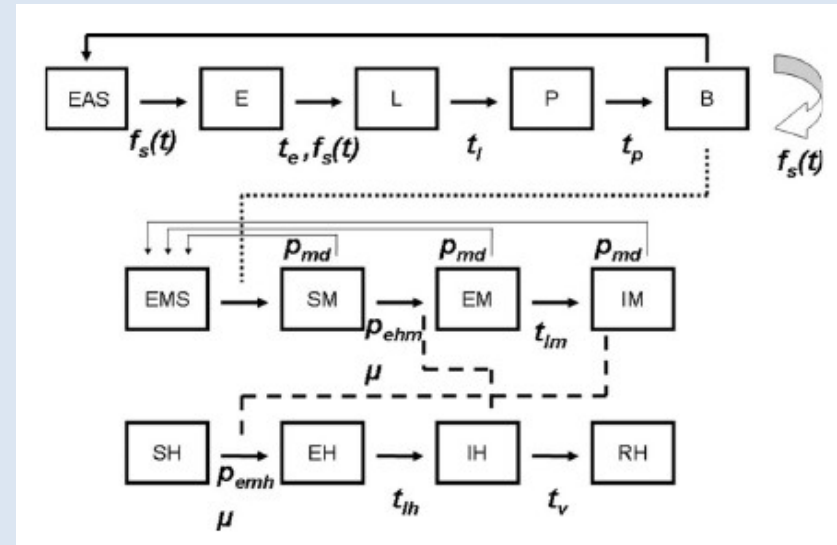

Why SI ?

The Model Structure

Global and local spatial Indices of segregation:

In this **epidemiological context**, indices of segregation are used to depict the potential contact between infected and susceptible individuals.

*Depends of overall
population composition*

$$exp_{(m,n)} = \sum_{j=1}^J \frac{N_{jm}}{N_m} \cdot \frac{L_{jn}}{L_j},$$

The spatial segregation

Experiment A. Moore neighborhood with a centralized initial disease focus;

Experiment B. Moore neighborhood with initial infected people randomly scattered;

Experiment C. Activity-space neighborhood with a centralized disease focus;

Experiment D. Activity-space neighborhood with initial infected people randomly scattered.

$$\underline{L=101, I(0)=5\%}$$

The Experiments

Combining the Moore neighborhood with a centralized initial disease focus, 79% of the individuals in the surroundings of an infected entity are also infected. Only 1% of the individuals in the surroundings of a healthy entity are infected.

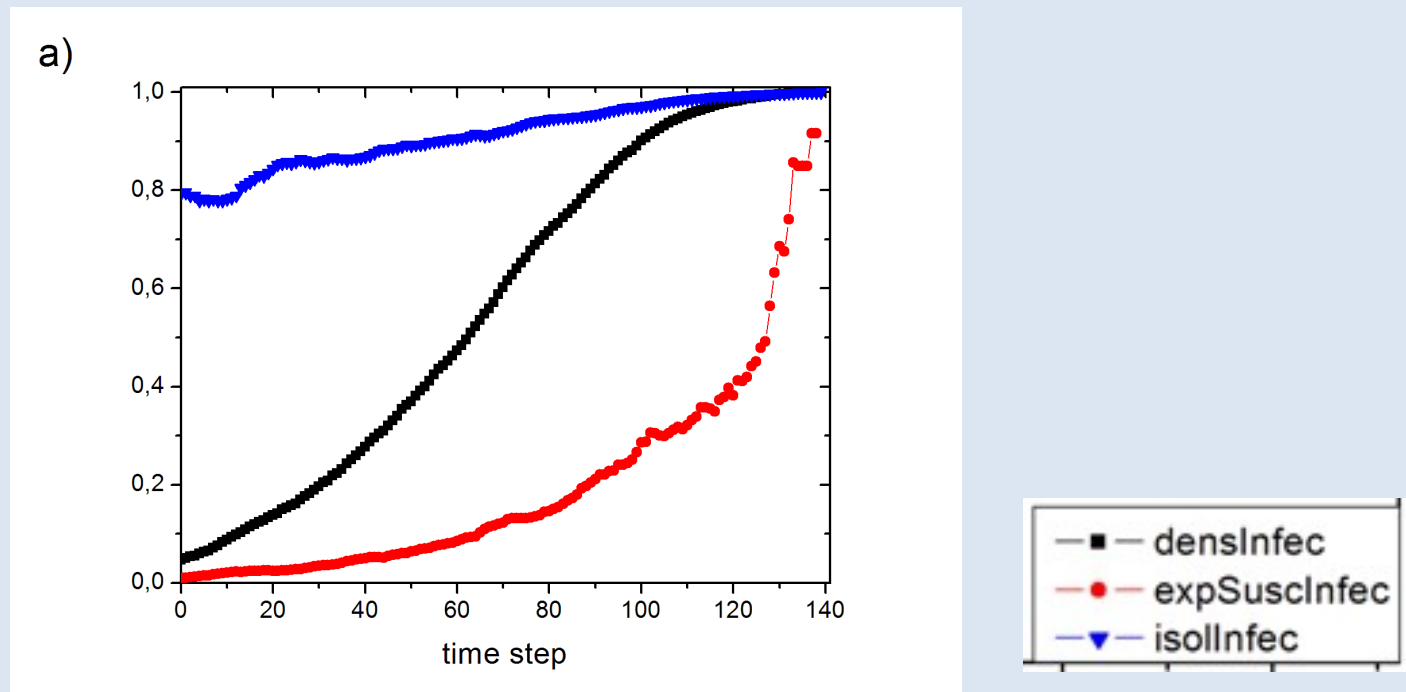

Results

Activity-space neighborhood includes a non-contiguous component - the initial isolation of infected individuals strongly decreases during the first iterations of the simulation.

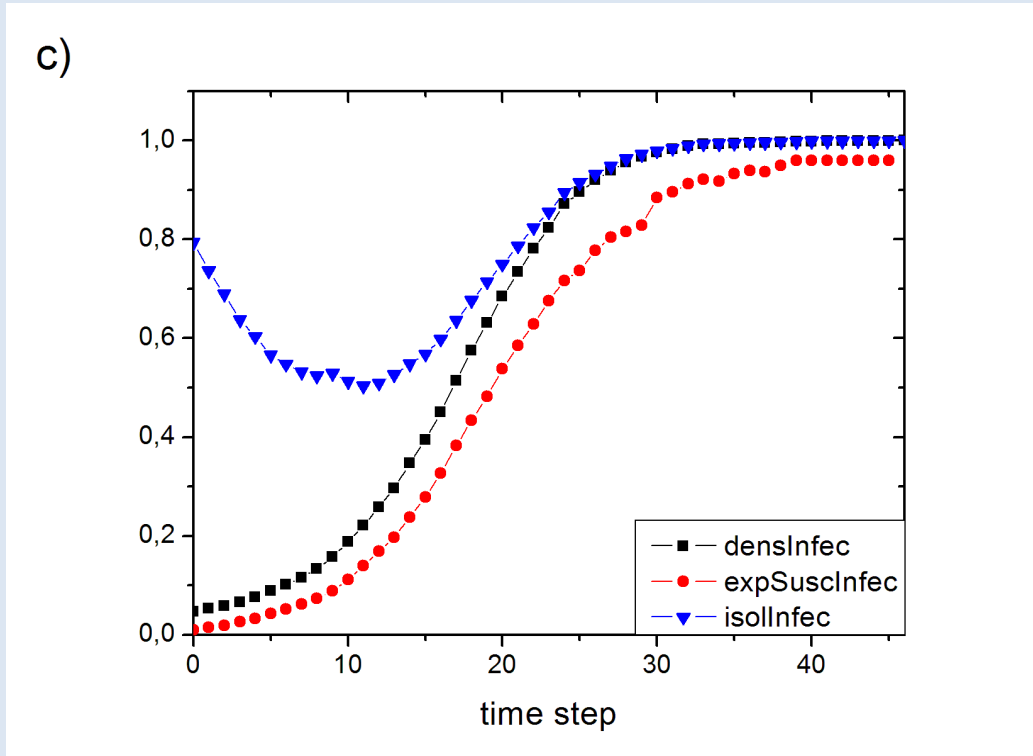

In the space:
secondary foci -
during the
individual's
work or school
activities

Results

R e s u l t s

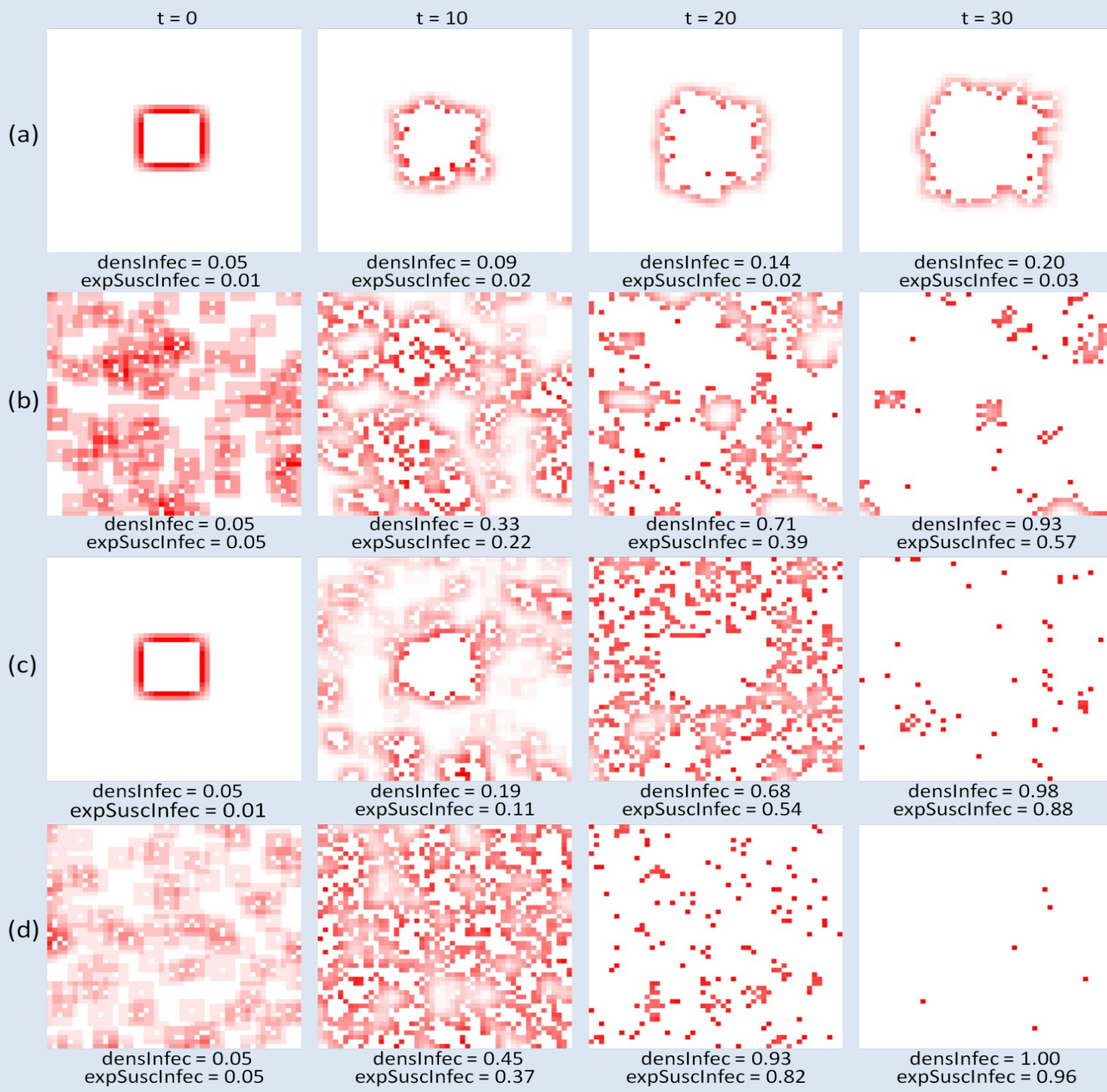

- This work investigated the effects of **neighborhood structures** (and **initial conditions**) on disease spreading through a compartmental epidemiological CA-model.
- Is used the concept of **activity space** on an epidemiological context, to explore a neighborhood type that includes not only places surrounding the residential location of individuals.

Remarks

- **Local** and **global** indices of isolation and exposure, normally applied for measuring **segregation** between social groups, were adopted in an epidemiological context.

Remarks

- **Carneiro, T. G. S. (2006).** Nested-CA: a foundation for multiscale modeling of land use and land cover change. In: Computer Science Department - INPE, São José dos Campos, SP.
- **Feitosa, F. F. et. al. (2007).** Global and local spatial indices of urban segregation. International Journal of Geographical Information Science, v. 21, n. 3, p. 299-323.
- **Santos, L. B. L. et al. (2009).** Periodic forcing in a three-level cellular automata model for a vector-transmitted disease. Physical Review. E, Statistical, Nonlinear, and Soft Matter Physics (Print), v. 80, p. 016102.

REFERENCES

Thank you!



santoslbl@gmail.com